



** Available up to 100 GPM systems*

Aquavar ABII

VARIABLE SPEED CONSTANT PRESSURE SYSTEMS

FEATURES

The AB2 variable speed pump controller and complete booster package kits, provide an economical answer for municipal water district customers with low water pressure. Both domestic and light commercial applications can benefit. As water use increases, the controller changes pump speed to maintain pressure. Large supply tanks are eliminated and less wear and tear on your pump and motor.

Think of it as "Cruise Control" for your pump! The AB2 is available with a range of flow rates to handle homes with up to four baths, irrigation, filtration and fire suppression systems. Light commercial applications up to 100 GPM at 45 PSI boost. The AB2 is available as either a separate controller or as part of a complete pump package with everything you need to plumb it to a domestic water line.

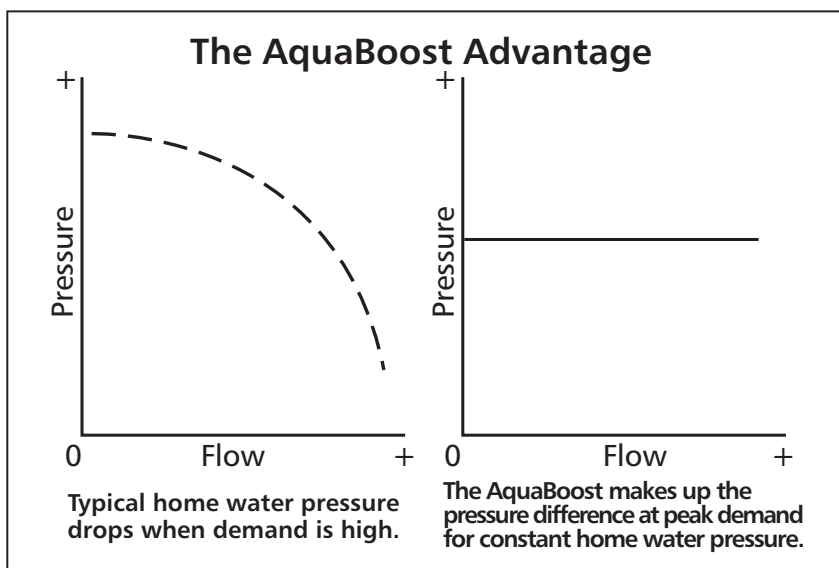

INPUT AND OUTPUT POWER (VOLTAGE AND PHASE)

- All 1AB2 and 2AB2 require single-phase input power
 - All will work on 1Ø, 208-230V input power
 - 1151AB2's will work on 1Ø, 115V input power
- All controllers output three-phase, 230 Volt power
- All pumps are equipped with three-phase motors

*1AB2 - Controller (1151AB2 for 115V)

- 4.2 Amp, 208-230 V, single phase input
- 1 HP variable speed controller
- Wall mount set • Transducer • Pre-wired
- Pump and tank not included

2AB2 - Controller

- 6.9 Amp, 208-230 V, single phase input
- 2 HP variable speed controller
- Wall mount set • Transducer • Pre-wired
- Pump and tank not included

*1AB2LB1035

- 1 HP controller • Wall mount set
- LB stainless steel jet pump • Transducer
- Discharge tee • V6P tank, pressure gauge
- Controller is pre-wired to the pump.
Flows to 15 GPM.

2AB21MC1F2B2

- 2 HP controller • Wall mount set • 208-230 V input
- MCC cast iron / stainless steel pump
- Transducer • V6P (2 gallon) tank and pressure gauge
- Controller is pre-wired. Flows to 27 GPM.

2AB21MC1G2A2

- 2 HP controller • Wall mount kit • 208-230 V input
- MCC cast iron / stainless steel pump
- Transducer • V6P (2 gallon) tank and pressure gauge
- Controller is pre-wired. Flows to 32 GPM.

*1AB21HM1E2D0

- 1 HP controller • Wall mount kit • 208-230 V input
- HMS stainless steel pump • Transducer
- V6P (2 gallon) tank and discharge pipe tee
- Controller is pre-wired. Flows to 20 GPM.

*1AB22HM1E2D0

- 1 HP controller • Wall mount kit • 208-230 V input
- HMS stainless steel pump • Transducer
- V6P (2 gallon) tank, pressure gauge and discharge pipe tee
- Controller is pre-wired. Flows to 30 GPM.

2AB22HM1F2E0

- 2 HP controller • Wall mount kit • 208-230 V input
- HMS stainless steel pump • Transducer
- V6P (2 gallon) tank, pressure gauge and discharge pipe tee
- Controller is pre-wired. Flows to 30 GPM.

**3AB2LCB1H2D0

- 3 HP controller • Wall mount kit • 208-230 V input
- LCB stainless steel pump • Transducer
- Pressure gauge and discharge pipe tee
- Controller is pre-wired. Flows to 50 GPM.

**2AB22MC1G2D2

- 2 HP controller • Wall mount kit • 208-230 V input
- MCC cast iron/stainless steel impeller pump
- Pressure transducer
- Pressure gauge, 1¼" bronze discharge tank tee
- Controller and motor are pre-wired. Flows to 80 GPM.

**5AB22MC1J2K2

- 5 HP controller • Wall mount • 208-230 V input
- MCC cast iron/stainless impeller pump
- Pressure transducer
- Pressure gauge, 1¼" bronze tank tee
- Controller and motor are pre-wired. Flows to 100 GPM.

**5AB2LCC1J2D0

- 5 HP controller • Wall mount • 208-230 V input
- LCC stainless steel pump • Pressure transducer
- Pressure gauge, 1¼" bronze tank tee
- Controller and motor are pre-wired. Flows to 70 GPM.

* 1 HP available in 115 input volt models, add a 115 prefix to order number; ex. 1151AB2LB1035.

** Tank not included, order separately.

SYSTEM SELECTION

PSI BOOST	2-10 GPM	20 GPM	30 GPM	40 GPM	50 GPM	60 GPM	70 GPM	80 GPM	90 GPM	100 GPM
20	1	3	3	5	5	9	9	9	10	10
25	1	3	3	9	9	9	9	10	10	10
30	1	3	3	9	9	10	10	10	10	10
35	1	3	3	9	9	10	10	10	10	10
40	1	3	3	7	7	10	10	10	10	10
45	1	3	3	7	8	10	10	10	10	10
50	1	3	4	7	8	10	10	10	10	
55	1	3	4	7	8	10	10			
60	1	4	7	8	8					
65	2	4	7	8	8					
70	2	4	8	8						
75	4	4	8							
80	4									

*1	1AB2LB1035 (1 HP, stainless steel pump, 1" discharge, 1¼" suction)
*2	1AB21HM1E2D0 (1 HP, stainless steel pump, 1" discharge, 1¼" suction)
*3	1AB22HM1E2D0 (1 HP, stainless steel pump, 1" discharge, 1¼" suction)
4	2AB22HM1F2E0 (1½ HP, stainless steel pump, 1" discharge, 1¼" suction)
5	2AB21MC1F2B2 (1½ HP, cast iron pump, 1" discharge, 1¼" suction)
6	2AB21MC1G2A2 (2 HP, cast iron pump, 1" discharge, 1¼" suction)
7	3AB2LCB1H2D0 (3 HP, stainless steel pump, 1" discharge, 1¼" suction)
8	5AB2LCC1J2D0 (5 HP, stainless steel pump, 1" discharge, 1½" suction)
9	2AB22MC1G2D2 (2 HP, cast iron pump, 1¼" discharge, 1½" suction)
10	5AB22MC1J2K2 (5 HP, cast iron pump, 1¼" discharge, 1½" suction)

* 1 HP available in 115 volt input models. See Price Pages.

Items 7 thru 10 do not include tank. Recommend bladder tank, sized to 10% of pump flow (gpm).

NOTE: PSI is boosting pressure, NOT total system pressure.

AQUAVAR ABII CONTROLLER FEATURES

Input Power* – 208-230V ±15%, single phase (controller only)

Output Power – Up to 230V three phase (based on input voltage). Motor rated for 208-230V, ±10%.

Maximum Output Current – 4.2 amps - 1AB2 (1 HP)
– 6.9 amps - 2AB2 (2 HP)

Input Controls – Up and down buttons to set pressure.

Signal Lights – Power on, pump running, inverter stopped, pump stopped, standby, faults/errors.

Electrical Efficiency – Over 95% at full load

Protection Against – Short circuit, under voltage, overload, motor temperature, dead heading, run out, suction loss, sensor fault, bound pump, over voltage, static discharge. **Note:** Suction loss/run out is set for minimum 10 psi at discharge!

Ambient Temperature – 34° F to 104° F

Maximum Humidity – 95% at 104° F, non-condensing

Air Pollution – Avoid mounting in areas with excessive dust, acids, corrosives and salts.

Approvals –  

Controller Enclosure – Outdoor, NEMA 3R, IP 43 (Rain-tight)

Mounting – Wall mount with mounting hardware.

Cooling – Convection with cast aluminum heat sink.
– 3 HP, 5 HP with temperature fan

Transducer – 0.5 - 4.5 VDC with 5 VDC power supply, 100 psi range, 10-foot 3-wire shielded cable.

Input Wire – 5 feet of 14, 10 or 8 gauge cable. Depending on size, cable is pre-wired to controller and motor conduit box.

Output Wire – 10 feet of 14 gauge cable. Cable is pre-wired to controller and pump motor (when provided).

*Low input voltage may affect motor operation.

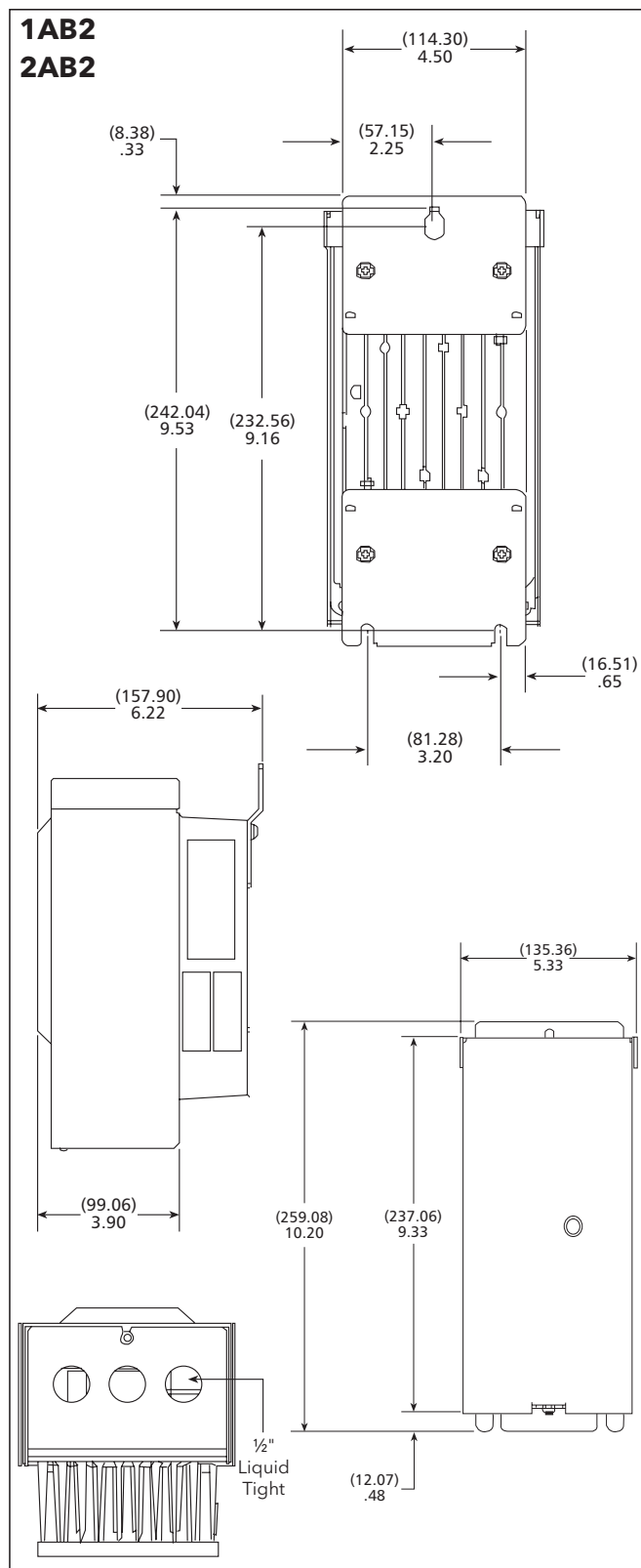

PRESSURE RANGE

Nominal Range – Field adjustable from 20 - 85 psi, total system pressure.

WARNING DO NOT SET REQUIRED SYSTEM PRESSURE ABOVE 85 PSI. SEVERE DAMAGE TO PLUMBING COULD RESULT. PLUMB RELIEF VALVE OUTSIDE OR TO A DRAIN.

SUGGESTED AB2 INSTALLATION FOR MUNICIPAL WATER SYSTEM

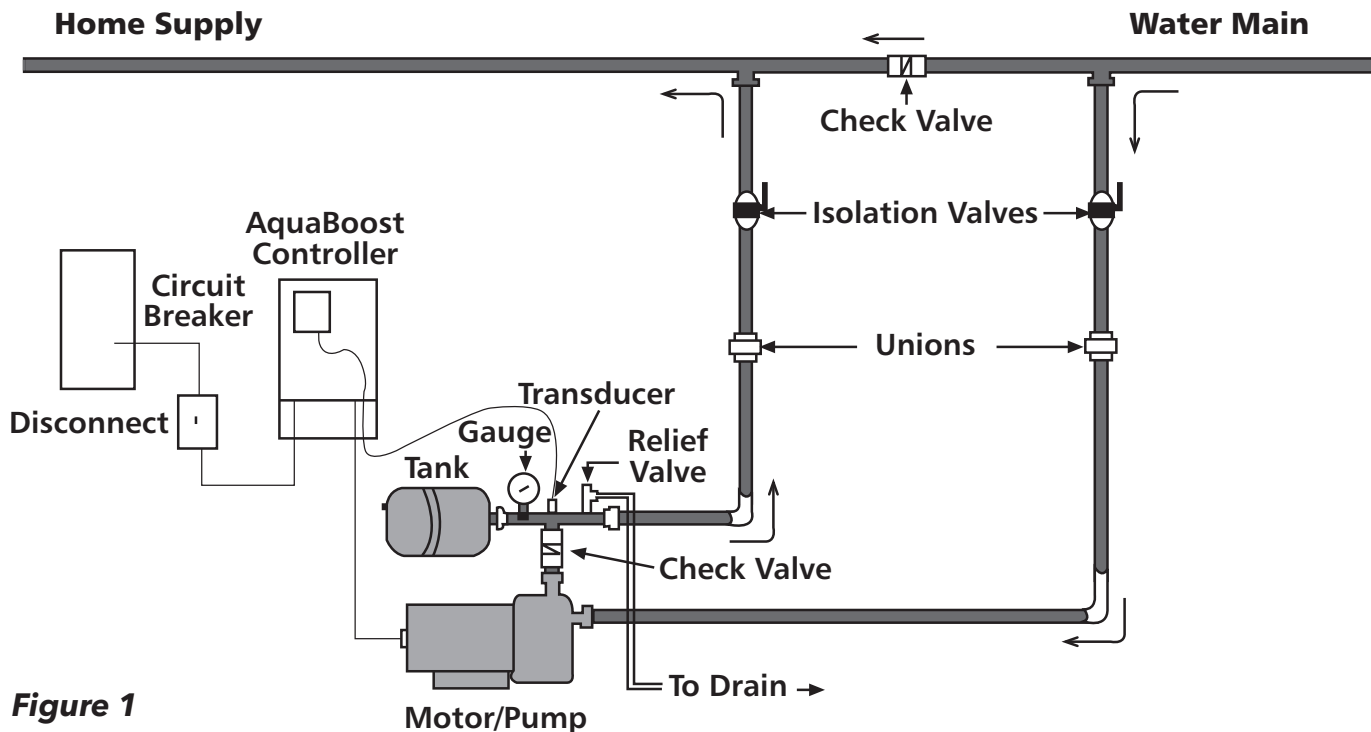

Figure 1

SUGGESTED AQUABOOST INSTALLATION FOR WELL PUMP SYSTEM

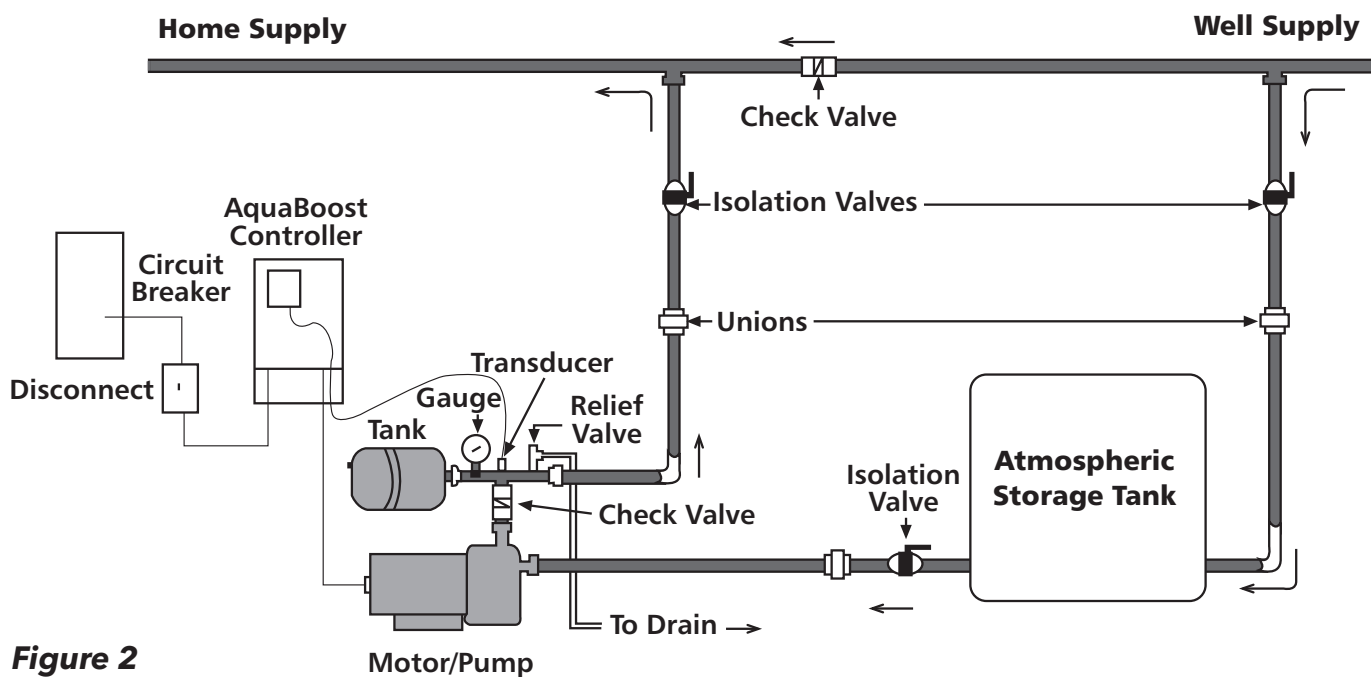
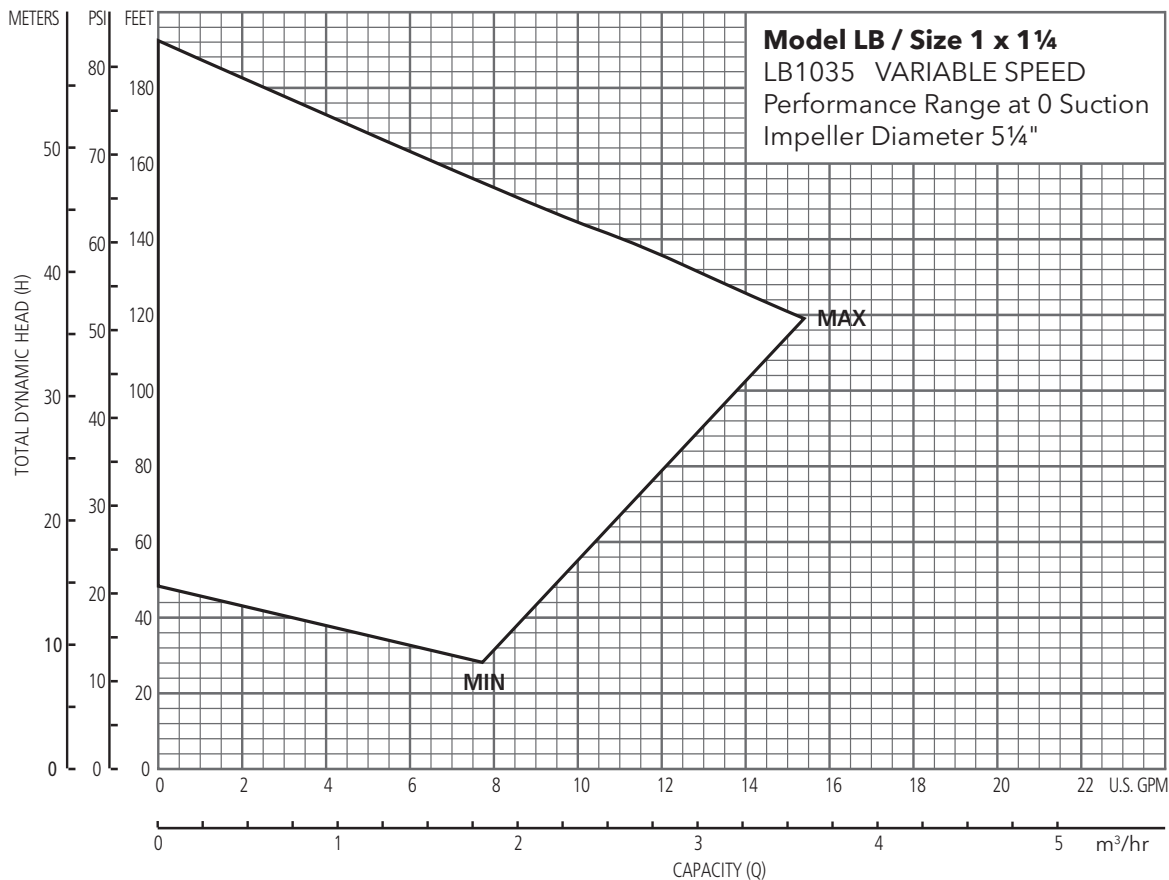
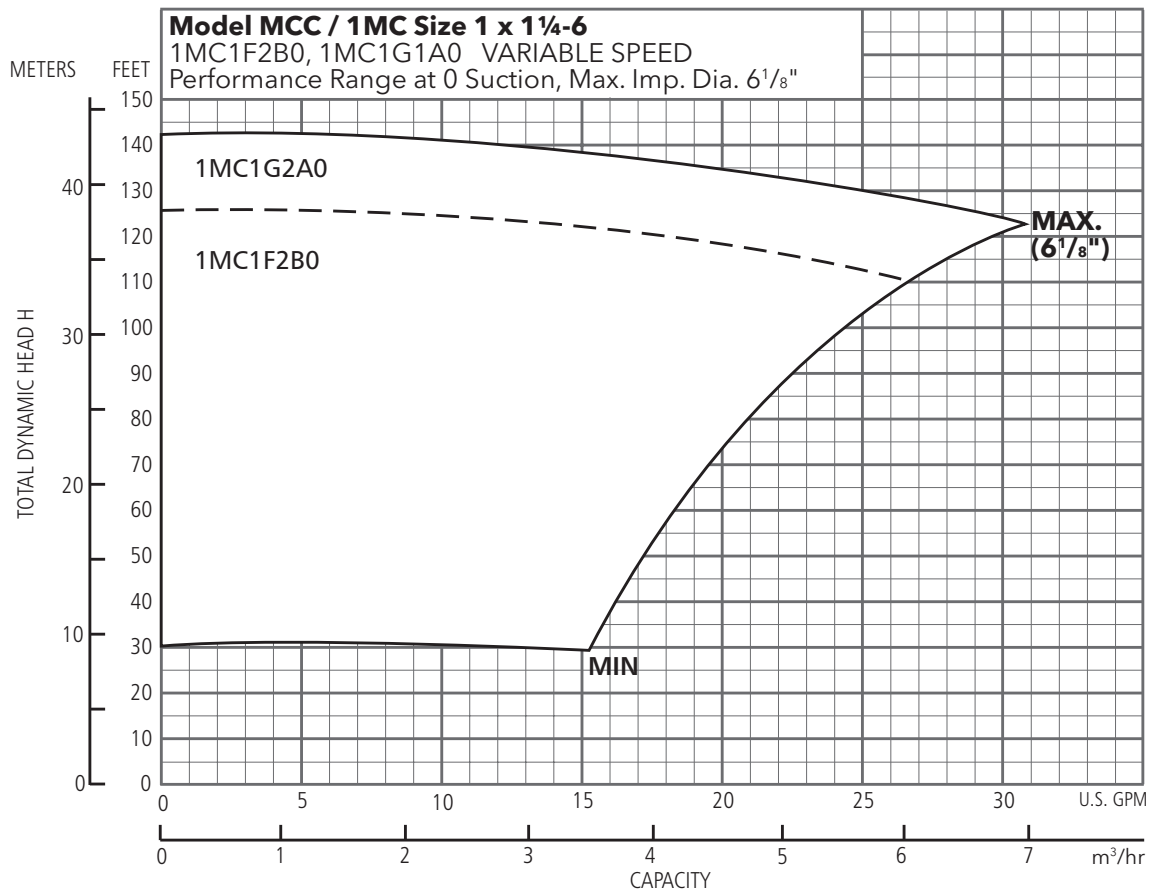
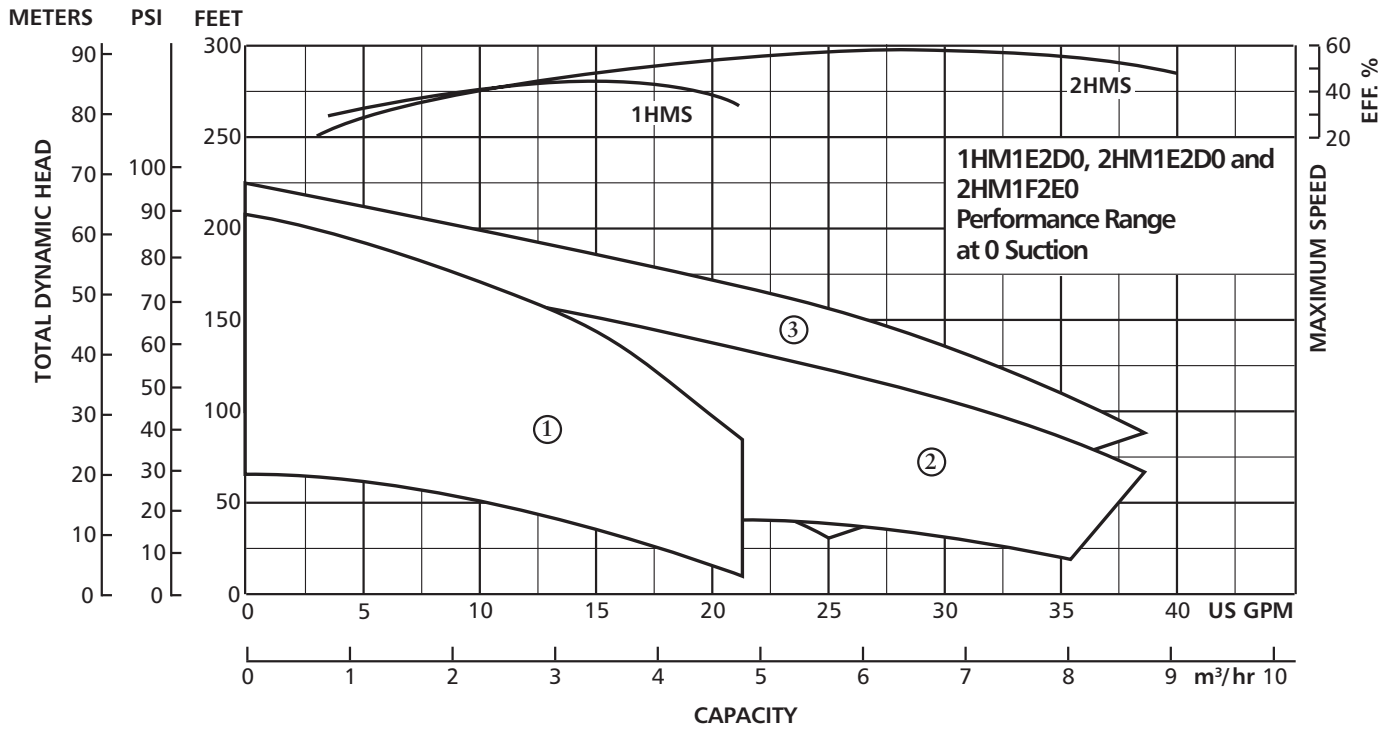
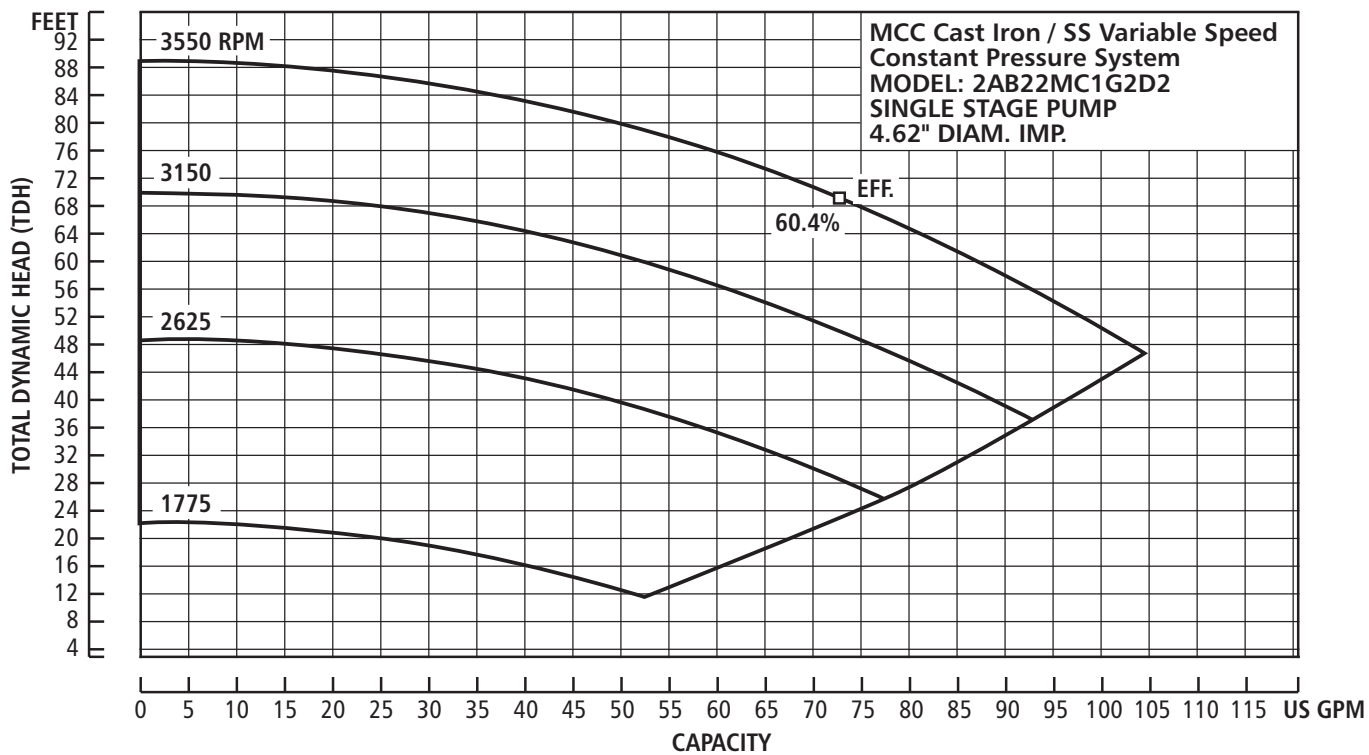
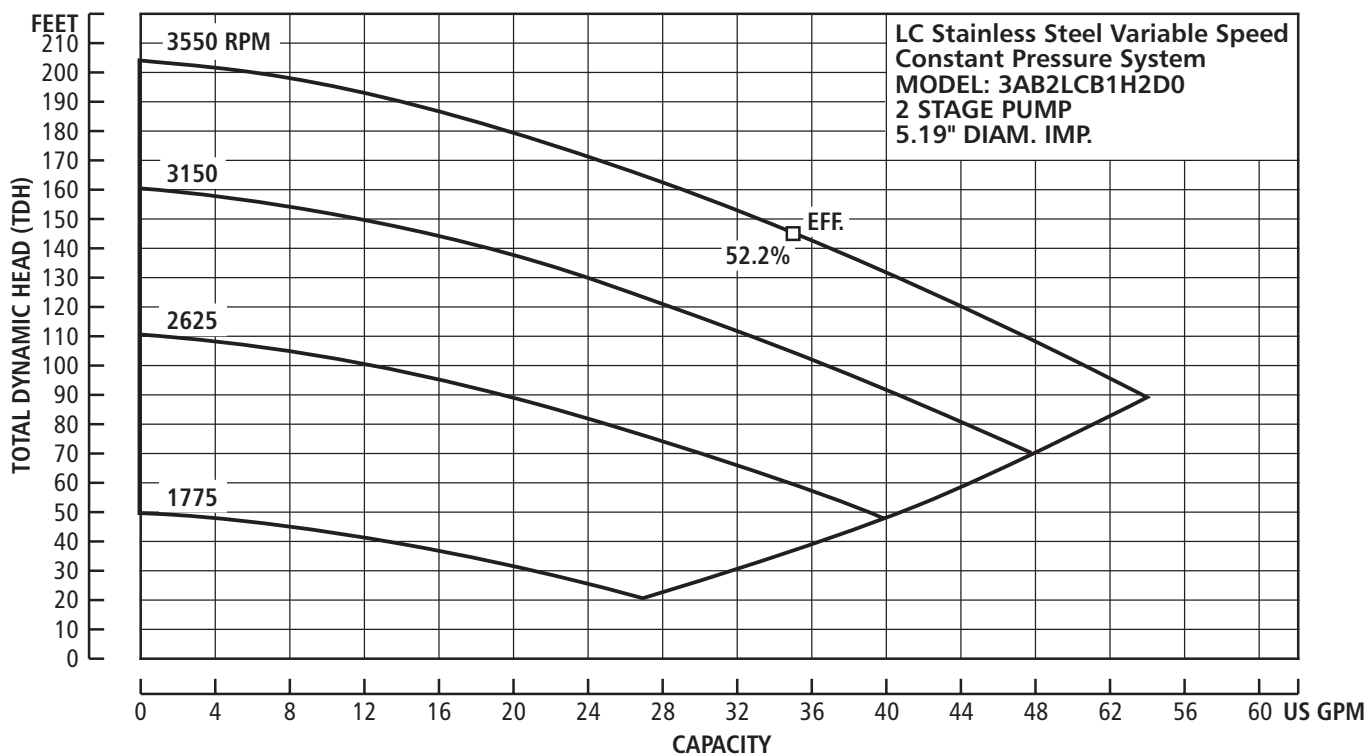

Figure 2





- ① Curve represents pump model 1HM1E2D0.
- ② Curve represents pump model 2HM1E2D0.
- ③ Curve represents pump model 2HM1F2E0.



NOTE: Curves indicate boost pressure.

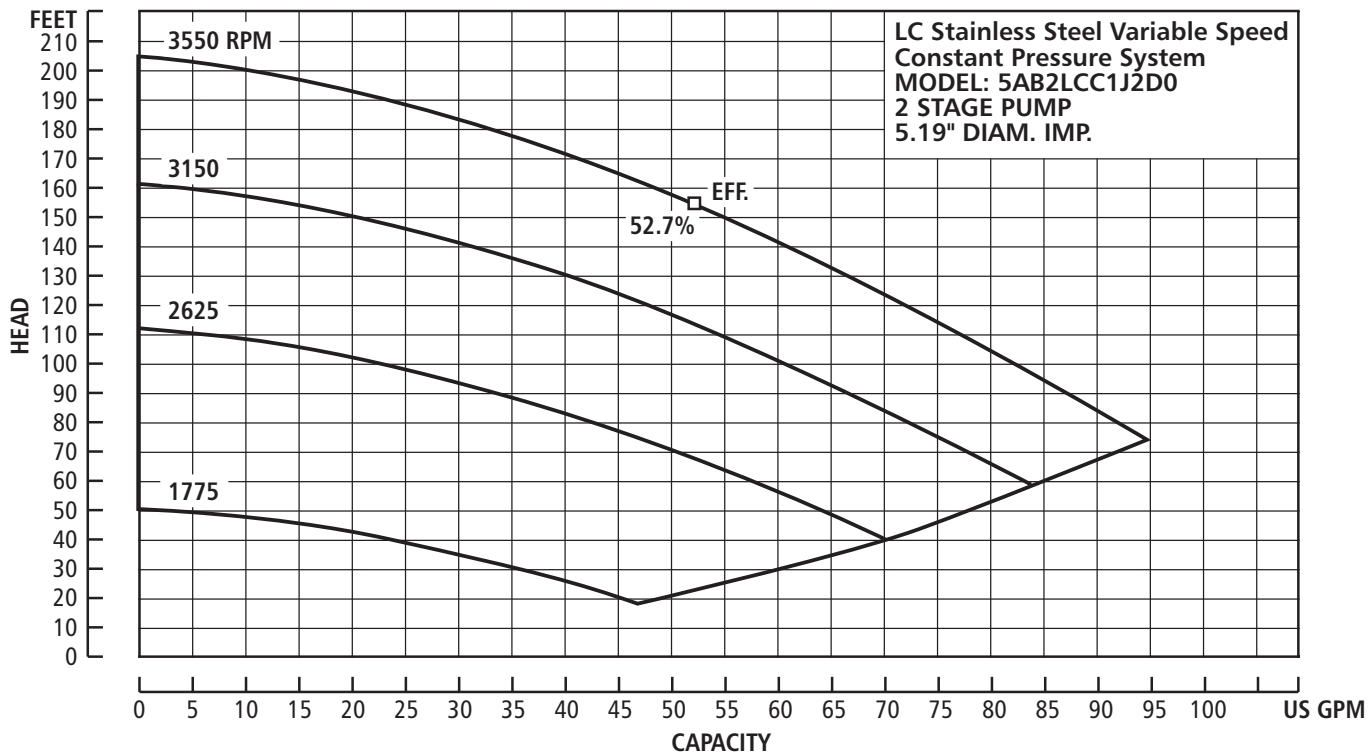
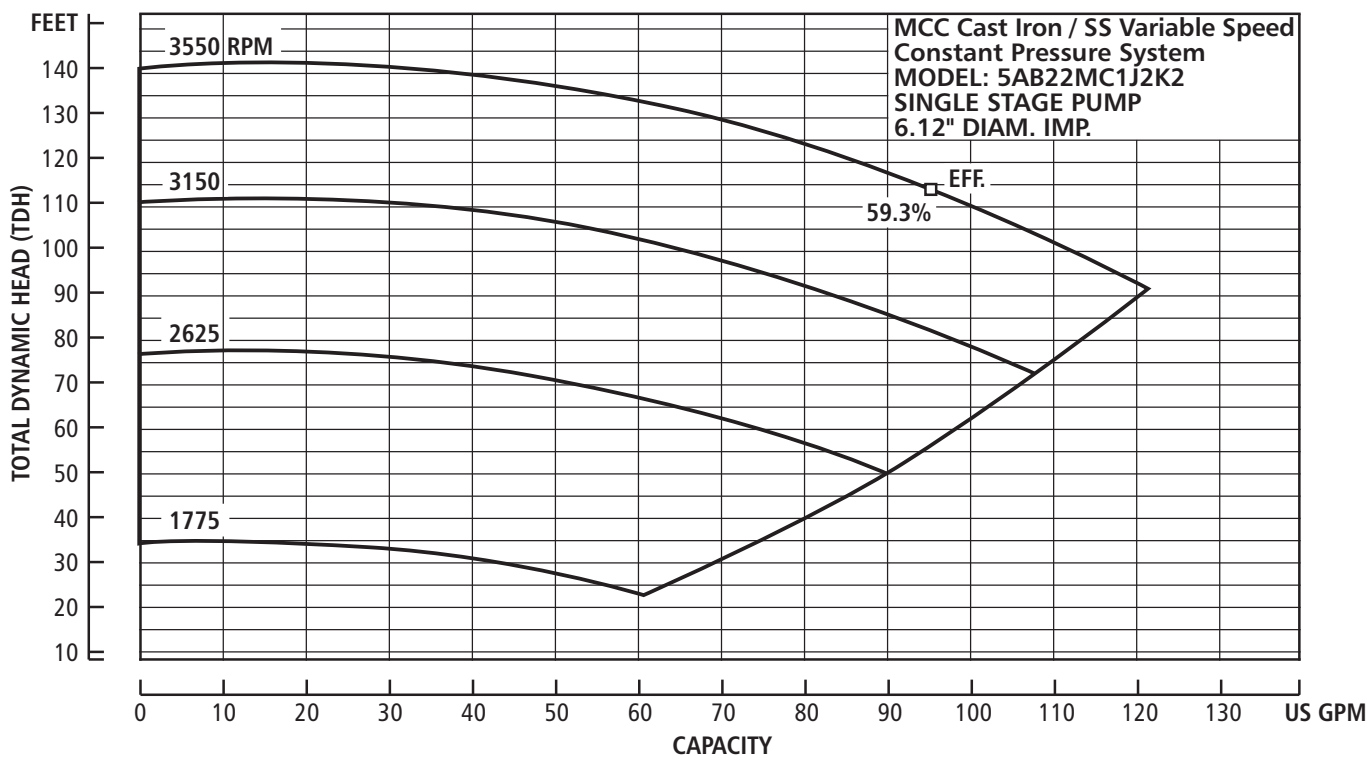

NOTE: Curves indicate boost pressure.

DIMENSIONS (For Reference Only - Do not use for construction purposes)

MCC PUMP (1MC1G2A2 AND 1MC1F2B2) WITH TANK AND TEE

Capacity – to 32 GPM (1MC1G2A2)
 – to 27 GPM (1MC1F2B2)

Rotation – Right hand clockwise,
 viewed from motor end

Materials – Cast iron casing
 316 stainless steel impeller

Motor – 1½ HP, ODP, Three Phase, 208-230/460V
 – 2 HP, ODP, Three Phase, 208-230/460V

Pipe Connections – 1 x 1¼ NPT

Maximum Temperature of Water – 120° F
NOTE: Tank Liquid Temperature Limit is 120° F
 Pump Liquid Temperature Limit is 212° F

Maximum System Working Pressure – 85 psi

Seal – Carbon / Silicon Carbide / EPR

*Overload protection, starters, heaters not required.
 Dimensions are in inches.*

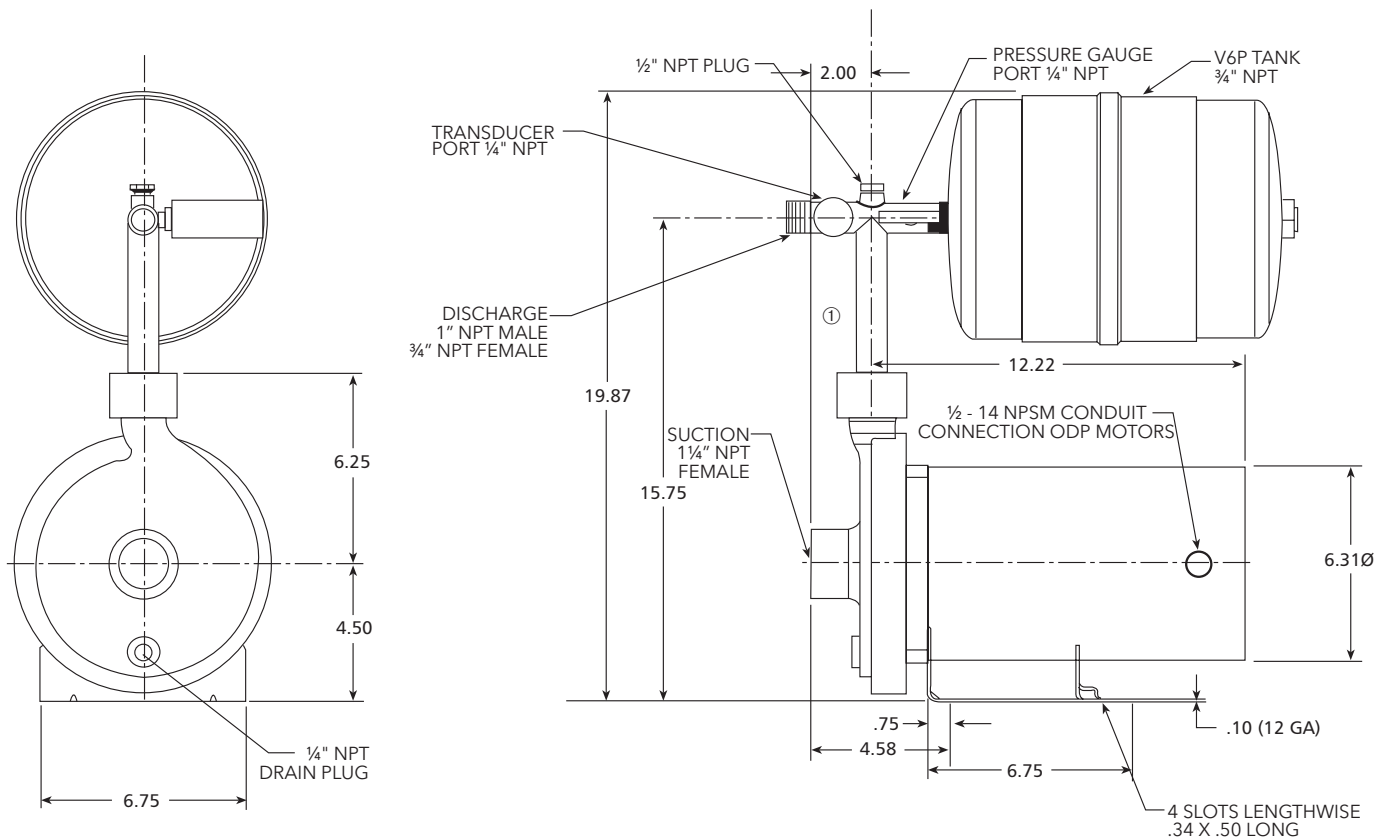

Approximate Packaged Shipping Weight – 75 lbs.

① Add the Check Valve dimension to this Reference Dimension

DIMENSIONS (For Reference Only - Do not use for construction purposes)

HMS PUMPS (1HM1E2D0, 2HM1E2D0)

Capacities – to 20 GPM (1HM)
to 38 GPM (2HM4/2HM5)

Rotation – Right hand clockwise,
viewed from motor end

Materials – 316L stainless steel for all liquid
handling components

Motor – 1 HP, ODP, Three Phase, 208-230/460V (1HM/2HM4)
– 1.5 HP, ODP, Three Phase, 208-230/460V (2HMS5)

Pipe Connections – 1 x 1 1/4 NPT

Maximum Temperature of Water – 120° F
NOTE: Tank Liquid Temperature Limit is 120° F
Pump Liquid Temperature Limit is 212° F

Maximum System Working Pressure – 85 psi

Seal – Carbon / Silicon Carbide / EPR

Overload protection, starters, heaters not required. Dimensions are in inches.

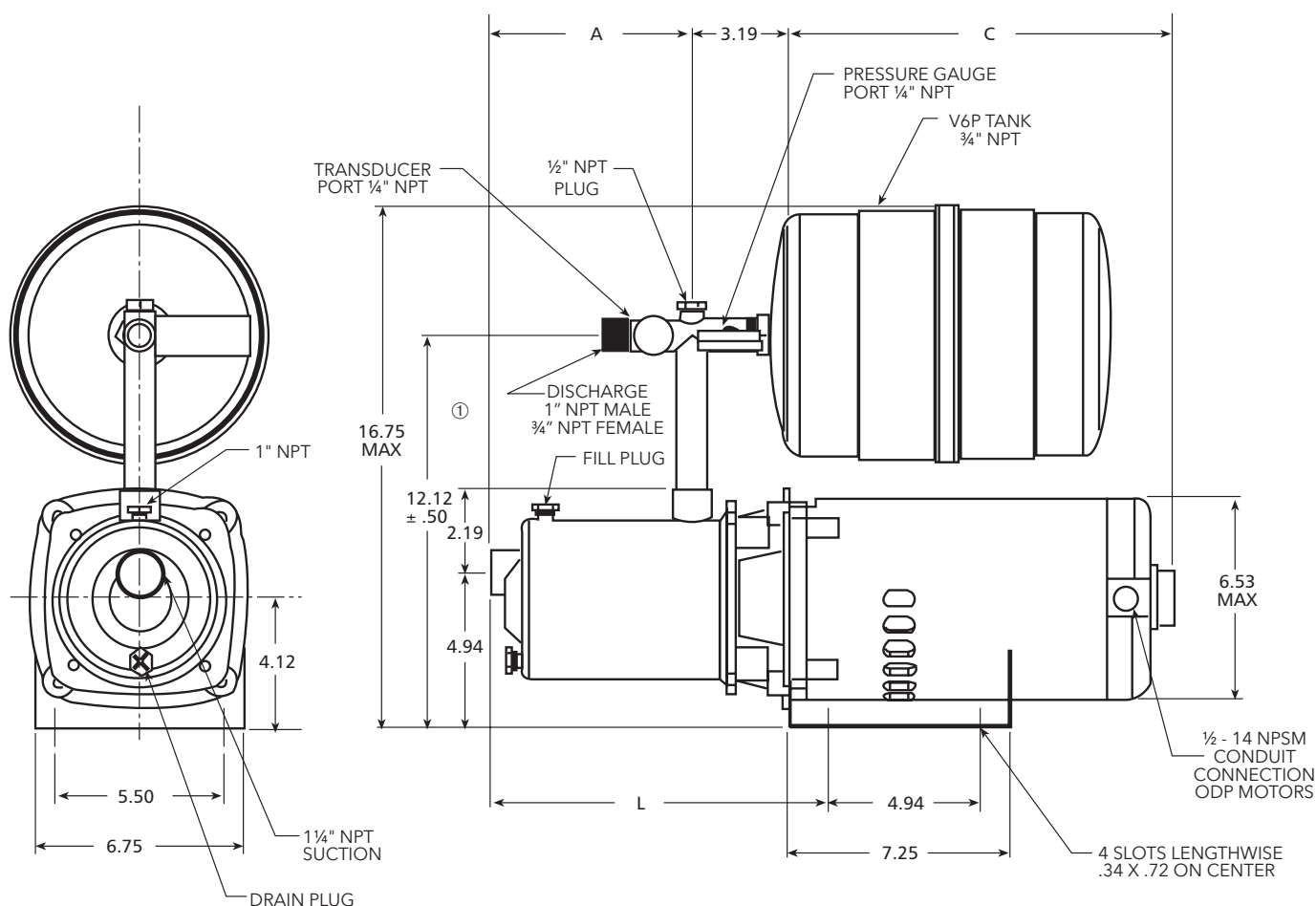

AQUABOOST	A	L	C	MOUNTING
1AB22HM1E2D0	5.75	10.75	11.62	View B
1AB21HM1E2D0	5.75	10.75	11.12	View A
2AB22HM1F2E0	6.73	11.75	11.62	View B

Approximate Packaged Shipping Weight – 55 lbs.

① Add the Check Valve dimension to this Reference Dimension

ALTERNATE PUMP MODELS FOR USE WITH 1AB2 CONTROLLER

MCC – ½, ¾, 1 HP, 3 ph, ODP or TEFC motor versions

3642 – ⅓, ½, 1 HP, 3 ph, ODP or TEFC motor versions

GT073, GT103 – 3 ph, ODP or TEFC motor versions

HSC07, HSC10 – 3 ph, ODP or TEFC motor versions

HMS – ½, ¾, 1 HP, 3 ph, ODP or TEFC motor versions

5GB, 7GB – ½, ¾, 1 HP, 3 ph, ODP or TEFC motor versions

NPE – ½, ¾, 1 HP, 3 ph, ODP or TEFC motor versions

NPO – ½, ¾, 1 HP, 3 ph, ODP or TEFC motor versions

MCS – ½, ¾, 1 HP, 3 ph, ODP or TEFC motor versions

ICS – ½, ¾, 1 HP, 3 ph, ODP or TEFC motor versions

LB – ½ and ¾ HP, 3 ph, ODP or TEFC motor versions

Note: These pumps are not currently offered as a packaged kit, from Goulds Water Technology.

All units require three phase motors.

Size pumps and controllers according to service factor amps of the motor.

ALTERNATE PUMP MODELS FOR USE WITH 2AB2 CONTROLLER

3642 – 1½, 2 HP, 3 ph, ODP or TEFC motor versions

GT – 1½, 2 HP, 3 ph, ODP or TEFC motor versions

HSC – 1½, 2 HP, 3 ph, ODP or TEFC motor versions

HMS – 1½ HP, 3 ph, ODP or TEFC motor versions

10GB – 1½, 2 HP, 3 ph, ODP or TEFC motor versions

NPE – 1½, 2 HP, 3 ph, ODP or TEFC motor versions

NPO – 1½, 2 HP, 3 ph, ODP or TEFC motor versions

MCS – 1½, 2 HP, 3 ph, ODP or TEFC motor versions

ICS – 1½, 2 HP, 3 ph, ODP or TEFC motor versions

Note: These pumps are not currently offered as a packaged kit, from Goulds Water Technology.

All units require three phase motors.

Size pumps and controllers according to service factor amps of the motor.

SUBMERSIBLE PUMPS

Use Aquavar SOLO or S-Drive controllers for submersible applications, they have filters built-in and are programmed for submersibles.

PACKAGED HARDWARE WITHOUT PUMP AND MOTOR (SEE PRICING PAGE)

Part Number 15K40

KIT INCLUDES:

- 1) Tank - V6P (2 gallons)
- 2) 1" Bronze Discharge Tee - AV20-6
- 3) Pipe Plug - ½", 6K68
- 4) Pressure Gauge - AG5 (1 - 100 PSI)



Xylem, Inc.
2881 East Bayard Street Ext., Suite A
Seneca Falls, NY 13148
Phone: (866) 325-4210
Fax: (888) 322-5877
www.xylem.com/brands/gouldswatertechnology

Goulds is a registered trademark of Goulds Pumps, Inc. and is used under license.
AquaBoost is a trademark of Xylem Inc. or one of its subsidiaries.

© 2012 Xylem Inc. BAQUABII March 2012